

## SECURO 24 PRO NCR1MUW04C

### IMPORTANT SAFEGUARDS

**When using electrical equipment, basic safety precautions should always be followed including the following:**

#### READ AND FOLLOW ALL SAFETY INSTRUCTIONS

1. Do not use outside
2. Do not mount near gas or electric heaters. Equipment should be mounted in locations and heights where it will not readily be subjected to tampering by unauthorized personnel.
3. The use of accessory equipment and replacement parts not recommended by the manufacturer may cause an unsafe condition.
4. Do not use this equipment for anything other than its intended purpose.
5. The voltage rating for this equipment is specified on the product label. Do not connect equipment to any other voltage.

#### SAVE THESE INSTRUCTIONS

### Specifications

Type: Addressable exit light for central battery system  
Addressing: Automatic, based on factory unique identification number  
Communication: Only with Schrack SECURO 24 PRO panels  
Mounting: Ceiling, sidewall, flag  
Light source: LED 1W, 50,000h operation, 6000K color temperature  
Viewing distance: 24 meters  
Housing color and material: White plastic  
Protection class: III  
Dimensions: 260mm x 49mm x 177mm  
Cable connection: Max. 2.5mm<sup>2</sup> cross-section solid or sleeved twisted wire  
Operating mode: Non-maintained / Maintained  
Mains voltage: DC 24-32V  
Max. input current: 0,08A  
Constant nominal ambient temperature range: 0°C < Ta < 45°C  
Protection: IP42  
Certificates: CE



**Modes of the LED indicator:** ■ Red ■ Green

Status	Led indicator
Normal mode, programmed	Constant
New device, not programmed	■ ■ ■ ■

## Dimensions

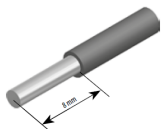
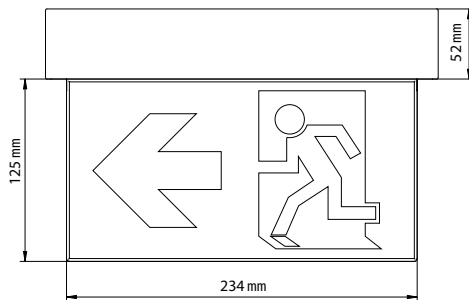
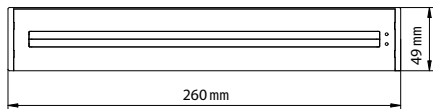

Use copper wire only  
14 -18 AWG, sol/str  
Max. Ø 2,5 mm<sup>2</sup>

## Wiring

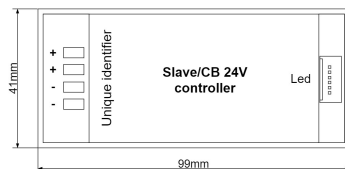

**Unique identifier** - SLxxxx00A0 copy this ID into commissioning book next to light's location and drawing text

**Cable wiring** - Connect the mains cable, the LED module to the luminaire using the diagram.

Correct phasing is important because of the communication line.

An incorrect connection will not cause a fault, but an incorrectly connected luminaire will also affect the function of the other luminaires on the line.

**Changing the LED** - Because of the LED's unique design, it can be changed by the manufacturer only.

### Ceiling mounting

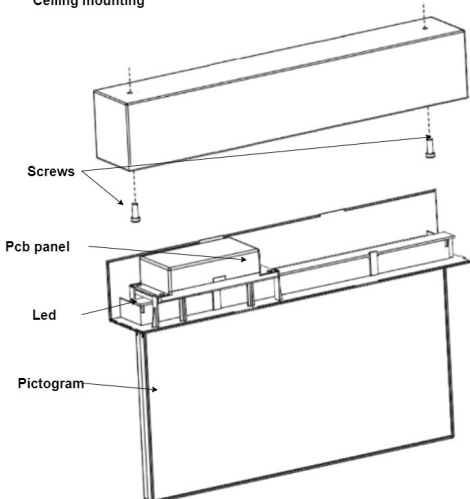

### Wall mounting

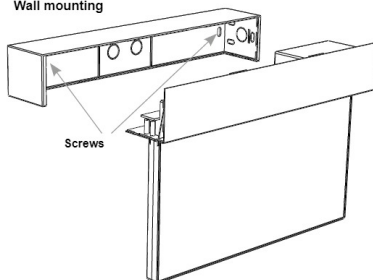

### Flag mounting

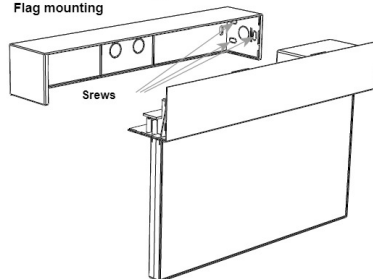

## CAUTION!

Works on the 24V mains may only be done from qualified personnel considering the local installation requirements.

Before installation the supply voltage must be switched off. The device works from SECURO 24 PRO system.

The mounting should be done only with the supplied retainers.

## Important!

In case of maintenance ensure that the device is disconnected from the power.

The producer will not take the responsibility for the damages caused by improper usage.